



from the Skin Out  
Spring AS XXVIII

## Upcoming Competitions and Displays

May Crown - Fighting Garb      July Coronation - Tourney Garb  
September Crown - Chamber Wear      12th Night '94 - Full Court Costume

### Arachnids Web Competitions

May Crown - Needle Lace  
July Coronation - Drawn Fabric Lace (no threads removed)  
September Crown - Crochet Lace  
12th night '94 - Bobbin Lace

From the Skin Out is the publication of the Costumers Guild of An Tir of the Society for Creative Anachronism, Inc. It is not an official publication of the SCA policies. All copyrights revert to the individual authors after publication in this journal.

Guild Membership including 4 issues of the From the Skin Out is \$12 (U.S. funds only please).

Please send FTSO subscriptions to the Guild Administrator Eduardo (D. McDonald) 2648 B Laukala Pl. Enumclaw, WA 98022

### From the Editor

Well, here we are already into May again! I have a new technical advisor this issue. Many thanks to Bjorn of Wolfshold and his magic computer!!!! I hope people are actually reading this letter, I have been hearing some grumbings as to the quality of my issues. Frankly, as I never hear from people I can only assume I am doing a good job. I print as many articles as I can get. If you don't think there are enough in each issue perhaps you should ask yourself how many articles you have actually sent me yourself.

It was also never the intent of this editor to tread on any toes. I was carrying on what I considered an honored tradition of this newsletter. I understand, however, that I am in error, therefore Auntie Anastasia's helpful hints has been changed.

I would appreciate anyone interested in taking over this newsletter to please contact me as soon as possible so we can discuss transition. I will be at all major Kingdom events as well as many others this tourney season.

Thank you for your kind attention.

In Service to An Tir and the Costumers Guild  
Baroness Anastasia Alexandrovna Andreevna

(2) From the Skin Out

### From the Administrator

Greetings unto the Costumers Guild of An Tir, from the Guild Administrator Master Eduardo Francesco Maria Lucrezia

Well it has been a long time since 12th night but we got a lot accomplished at that event and at the guild ranking meeting the Sunday after Madrone Baronial Banquet. I am sorry that some of you missed the meeting at 12th night we tried to let everyone know when it was going on and it was also posted in the site handout. If you have questions as to when the meetings will be please ask a guild officer or an autocrat. I have usually scheduled the meeting months in advance.

Please note the Guild directory page in the back of this issue. We have a full slate of officers. Thank you all for your continued support of the Guild. Now it would be nice to see some deputies. None of the officers want to stay in their jobs forever and we need to have some deputies to take over in case of exhaustion, a move, sickness, etc.

For those of you interested in costuming outside the SCA, Costume Con is coming to Seattle in 1996. Watch the Skin Out for more details. Anyone interested in being the Costume Con Reporter?

You will find in this issue, along with the articles, minutes from the 12th night meeting and other miscellaneous, a proposal for the new guild rankings. This is a proposal and is not set in stone. It is a

compilation of ideas that have been brought up and will be discussed and changed if the guild feels the need. Please feel free to write or to attend the meeting at the next crown event. The rankings will not be open to challenge until they have been incorporated into the bylaws and ratified by the guild. I would like to see this happen sometime before next 12th night, but I have no time table.

As I have said in the past I enjoy and encourage everyone to express their views to me in person or in writing concerning any matter involving the guild, but please if you would like a response include your return address. I can't and won't respond to letters that do not include this information.

### ARTICLES, ARTICLES, ARTICLES.

Please support the guild by writing one. We know you are out there and the newsletter is going to come out four times a year whether we have any or not, so please write. Also if you feel the quality of the newsletter, or the thickness of it is lacking you have it in your power to do something about it. WRITE.

I am writing this letter in April so the Guild fair has not yet taken place but it sounds like it is going to be a great success and I hope everyone enjoyed themselves and learned a lot. I hope that it will come to be a yearly event and that we as a Guild continue to participate.

A new magazine of interest to textile workers. "Piecework" the Premier issue is on the stands now. It is  
Spring '93 (3)

another great magazine from interweave Press. The issue out now has articles of knitting in the Middle Ages, two articles on embroidery, an article on Irish Crochet, a how-to article on Pine needle baskets and many more exciting tidbits. I have a copy and will bring it to May crown. This magazine is well worth the \$4 cover price.

Thank you all once again for all the support you have been giving the guild. And a special thank you to Isolde for all her work on the 12th night costume contest.

As always,  
Master Eduardo Francesco Maria  
Luerczia



(4) From the Skin Out

12th Night Minutes, Taken by  
Master Eduardo

The meeting took place as scheduled in the upper lounge of the site. There were 15 people that signed in and many more that dropped in and out throughout the meeting. White lilies were passed out to all who wanted one. There were many comments about the positive reaction to the lilies from the populace.

OFFICERS REPORTS

FTSO Editor - 79 subscriptions. She will be stepping down after 4 more issues. This will mean the new editor will have the time between 12th night and May Crown to produce their first issue. Miriam has volunteered to take it over. The administrator and the editor will be accepting written applications for the position. The cost of the newsletter is running between \$75 and \$100 per issue not including postage costs. The smaller format has reduced costs considerably. The editor will be changing deputies as of May crown issue. As always the FTSO needs articles.

CONTESTS DEPUTY

Not present ( see info included in this issue for an update on 12th night competition)

EXCHEQUER

Report given by Anastasia. We have more money than was originally thought. He is in the middle of doing the end of year report and will send it on to the administrator.

EDUCATION DEPUTY

Not present. The administrator wanted to make it clear that any workshop billed as A Costumers Guild Workshop should be cleared by this deputy. The deputy does not have to run the event or be involved in a large way but they MUST be informed of the workshop, the kinds of classes that will be offered and the teachers who will be there. This way the Guild workshops will have the same quality, and so classes are not repeated too often. Communication between the local group and the Kingdom level guild is essential if we are going to continue to have a Kingdom guild.

DRAPERS INVENTORY

Was running the drapers inventory table, and did not send a report.

SUB-GUILD REPORT

WEAVERS

Terra Pomaria had a class on Tapestry weaving

EMBELLISHERS

not present

REGIONAL OFFICERS

Avacal - Darcy - is rumored to want to resign, but have not received work from her directly. The administrator has a temporary replacement until we can open it up to the populace of Avacal. (Note: Darcy has now officially resigned)

Inlands - Nikita - They have been working on a pavilion with the help of Aisillin. Things are going well.

Northern - Sine - not present. She has mailed her report but it has not gone through the Canadian and US Christmas mail.

Rivers - Karena - Not present - Phoned in her report. Everything is going fine. The households of the area are busy

making garments.  
Summits - Rosemary - Not present  
Western - Tsuruko- This is her first meeting as the new representative for the Western region.  
We finally have a full slate of officers.  
Now what about deputies?.....

ADMINISTRATOR

Everything is going very well. Wants a time table for resignation. It was felt that the editor and the administrator should not resign at the same time. I July Coronation 94 a reasonable time? The assembly seemed to want Eduardo to stay as long as he felt he could. Eduardo will think about it. The Guild needs to create a criteria for the Gilded Lily. Now that the white lilies are going so well we need to bring the next step in. Anyone interested heading a committee? It was agreed that criteria should be developed but no one volunteered. The Guild will be involved in the Kingdom Guild Faire. See the Crier for more information. Godytha is retiring as Kingdom Minister of Arts and Sciences. The assembled recognized her amazing contribution to the Arts and Sciences of An Tir. The A&S pavilion needs to be finished. Should the Guild take this on as a project? The consensus was yes. Jean Louis has the walls and some money he will give these things to the Guild. The Guild handbook needs to be updated. This will happen after the rankings have been revised.

RANKINGS

There was much discussion on this topic. There will be a Costumers Guild meeting the Sunday after Madrone Baronial Banquet to discuss the rankings. The minutes of this meeting will be published in the FTSO for comment by the Guild.

The winners of the 12th night 93 Full Court Costume Contest are:  
Ariel de Courteney - Late period European  
Ellisif Angantyrrottir - Early period European  
Murakami Tsuruko - Non-European

Thanks to all who entered and we hope to see you next year. If you wish to see your scores please contact the contest coordinator.  
Prizes for this contest was a beautiful color book of Scissors.

NEWS FLASH NEWS FLASH  
NEWS FLASH

**Janet Arnold** is coming to Vancouver Community College September 14th and 15th. She will be doing 3 lectures. supporting features are: Rich and Fantastical cavalier dress and Queen Elizabeth's wardrobe unlocked. More information will be forthcoming.

"Everyone should dress well, according to his age and position in society. If he does not, it will be taken as a mark of contempt for other people".

Galateo (The Book of Manners) by Giovanni della Casa 1558

Helpful Hints from our Readers  
ITALIAN RENAISSANCE LORDS AND LADIES

Are you frustrated about sewing eyelets? Authentically you can just cut small holes, or, what I did was: using a large, sharp needle, and ribbon of thin width, simply sew in the laces. Or you can use rings - small washers work, as well as small

(6) From the Skin Out

plastic rings that can be found at hobby/craft stores. I've even heard that getting a chain-mail maker to give you some single rings work - but keep in mind what some metals can do to fabric when thrown into the wash together. To attach to your garment, stitch it (by hand) to the underside of the piece in a way which makes it laceable (if that's a word) but not too obvious. Apparently, Master Eduardo uses rings in his Italian garb - it is perfectly period and much less tedious than hand sewing all those holes.  
Elsbeth Iolanthe Kestrel  
information gleaned from Lionsgate Grand Ithra

#### Costuming Terms

##### **Ruche**

A pleated or goffered strip of lace net or linen lawn, worn around the neck. Ruches appeared in Spain in the first half of the 16th century, as tiny frills finishing neck and sleeves of the fine lawn masculine shirt. After the middle of the century the ruche became a fully developed ruff with lace edging.

##### **Russet**

a coarse peasant cloth of yellowish-red or grayish-brown used for everyday clothes in past centuries. Russet remains the name for such garments, also for the color.

##### **Vair**

Fur of the Russian or Siberian squirrel, a precious fur sewn in alternating gray and white pieces and worn by only kings, nobles, and prelates.

#### HOW TO DO RAISED APPLIQUE by Lady Catalina de Almeria y Tiermas

Applique dates back thousands of years. There are references to it in the Bible, and Egyptians used it to decorate their tents. Crusaders' flags and banners were frequently adorned with applique. Heraldic tabards, and many other garments were often intricately appliqued.

The word applique means "to lay on" from the French word *apliquer*. Although applique is basically stitching one fabric to another, the techniques and methods used to do this have been greatly refined and embellished over the years. The most common embellishments in the Middle Ages were beads, metallic thread, wire, and various embroidery stitches.

There are many different forms of applique but the one of interest herein is raised applique or stumpwork. Raised applique dates back to the fifteenth century Poland, Hungary, Germany, Austria, and Italy (figures 1&2). There are references and examples of English raised applique in the sixteenth century (figures 3&4). The Douce Bible given to Elizabeth I as a New Years gift in 1583-4 was covered in red velvet and embroidered in gold and silver wire and decorated with seed pearls (fig.5) Many of the pieces done were ecclesiastical garments and accessories, but there were also tapestries, gloves, boxes, pouches, and other items made for daily use. The "Devereaux Heirloom" is a bodice sent to Elizabeth I by the Countess of Leicester when her son,

the Earl of Essex was awaiting execution in the Tower of London. It is made of cloth of silver and worked in gold, silver, and silk threads. The design of different kinds of flowers twining amongst each other, and interspersed with insects, is done in canvas, silk, and crewel embroidery as well as raised applique (fig 6). Most of the pieces reflected scenes of every day life, gardens with people strolling through them, castles, villages, and tents at tournaments and on journeys. The figures were worked with great care to make them as life-like as possible, including wired limbs and embroidered faces and garments.

Although this art-form is known as stumpwork today, the name did not come into use until the Twentieth century. The Oxford Dictionary quotes the first use of the term from Burlington Magazine in 1904. There are several theories as to the origin of this name. The French word, *estompe*, meaning embossed is a possible origin. Also it has been theorized that the use of blocks of wood or stumps as "padding" under the stitchery could have contributed to the name. Medieval listings of embroidery stitches from schools and embroidered items from household inventories refer to it as raised embroidery, and this is how it will be referred to henceforth in this article.

There are several different techniques used in raised applique. One technique is to stitch directly over the padding which can be any of a variety of materials including felt, wool cotton, wood, layers of thread, even wire was used to shape hands

Spring '93 (7)

and branches.

Another technique is to cut a shape cut from two pieces of fabric, embellish them with fancy embroidery stitching, beads, etc.; stitch them together like a sandwich and then stuff them with wool or cotton to achieve a rounded form. This piece is then stitched onto the background fabric.

A third technique is applique that is separate from the background piece which is padded with layers of felt, and this is the technique detailed in the remainder of this article. Plan out the piece so that you have the exact size and placement of the applique pieces. Cut paper patterns to the exact size of the finished appliques. Using tailor's chalk, trace the pattern on a piece of unbleached muslin and on the fabric to be stitched on. A light box or table is useful for this step.

Cut paper patterns in consecutively smaller sizes than the pattern traced on the fabric (fig 7). The number of patterns will vary depending on the desired fullness of the applique. If a fuller applique is preferred, make more patterns will be necessary. Using these patterns, cut out pieces of felt; cutting as many as needed for the desired effect. Notice that the smaller piece of felt goes on the bottom. The pieces are stacked on top consecutively according to their size -- smallest to largest. The larger pieces will hang over on the edges. Loosely hand baste the felt to the muslin to hold it in place.

Place the top fabric, with the traced shape on it, in position over the felt and pin it to the muslin. Machine (8) **From the Skin Out**

baste slightly outside the edge of the traced pattern. Leave enough fabric outside the basting to fit into an embroidery hoop, and this will also provide the seam allowance (fig 8). Remove the pins and put the fabric in an embroidery hoop or on a needlepoint frame. Start stitching along the traced outline of the shape using the couching stitch (fig 9). If beadwork or other decorative embroidery stitches are to be used; this is when they should be done. Cut the excess fabric away leaving a 1 1/2 to 2 inch wide strip all around; this is the seam allowance. Remove the machine basting and cut straight into the seam allowance fabric at 1/2 inch intervals for easement (fig 10). Cut as close as possible to the edge of the stitching around the applique, but be careful not to cut the stitching. Apply Fray Check to the edges of the cut sections. Fold each section under, and hand stitch it to the muslin side of the piece.

After all of the applique pieces are finished, place them in their correct positions on the background fabric and pin. using a whip stitch (fig 11) or blind stitch (fig 12), attach the applique to the background fabric.

For a fuller look, push the edges of the applique in slightly while stitching it to the background fabric. Finish the background fabric in a manner appropriate to the piece being made.

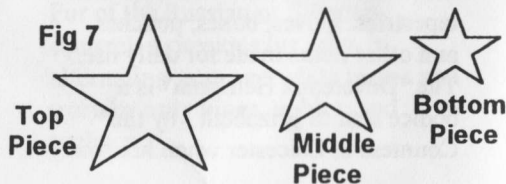

#### BIBLIOGRAPHY

1. BETTER HOMES AND GARDENS APPLIQUE, page 8
2. THE BIG BOOK OF APPLIQUE; by Virginia Avery, chapter 1.
3. CATALOGUE OF ENGLISH DOMESTIC EMBROIDERY; by John L. Nevinson, pages xxi-xxiii
4. THE COMPLETE GUIDE TO NEEDLEWORK TECHNIQUES AND MATERIALS; by Mary Gostelow, pages 61-66
5. ERICA WILSON'S EMBROIDERY BOOK, chapter 6
6. FUN WITH CREWEL EMBROIDERY; by Erica Wilson
7. McCALLS QUILTING, PATCHWORK, AND APPLIQUE ENCYCLOPEDIA, Volume IV, pages 100 & 105
8. STUMPWORK: THE ART OF RAISED EMBROIDERY; by Muriel Baker.

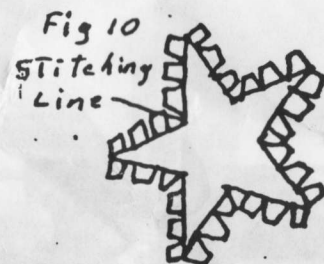
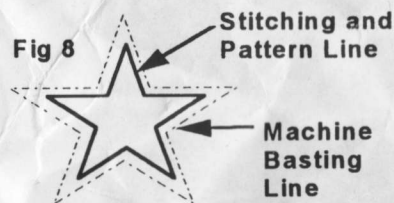

COUCHING Fig 9

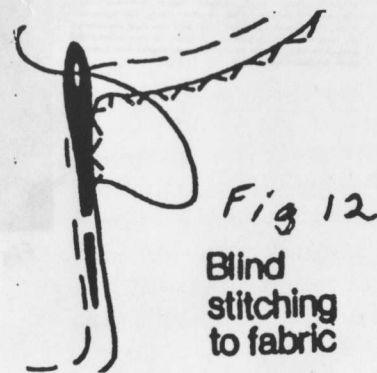
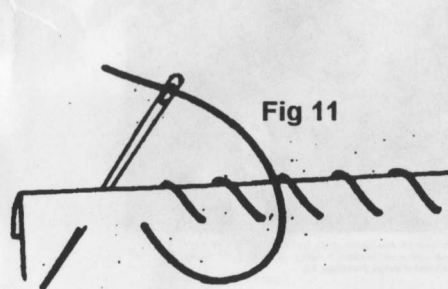
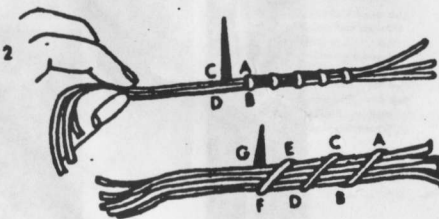
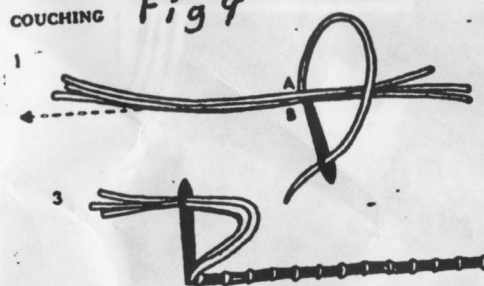



Fig 1

A crucifix, originally used as an orphrey cross on the back of a throne, made in Germany in the fifteenth century. The figures are beautifully delineated in raised work, with very close attention to the faces and hands. In general, the figures on these ecclesiastical pieces from the Continent are superior to the English ones. Courtesy of the Art Institute of Chicago.



Fig 2

Right-hand corner panel should depicting three men in a boat on the river Havel. It is signed by Wolfgang Popp.



Fig 3

In the lower left-hand corner of this paneling is the type of frame that was used in the sixteenth century. Museum of Art, Rhode Island School of Design, Providence, R.I.

The Bible in embroidered crimson velvet presented to Queen Elizabeth I. Bodleian Library



Fig 5

A book of prayers, handwritten by Elizabeth I as a child, with a cover embroidered by her in silver and light blue. A New Year's gift to her stepmother, Queen Katherine Parr. The pansies are padded and raised. Bodleian Library



TO OVE... REASO... AND  
 vertice... KATHERIN ELIZ...  
 both her... the first...  
 perpetual fibrous...  
 NOE ONELY knowing the affe...  
 ctions... and...  
 all godly...  
 towards...  
 powers...  
 replace...  
 and that...  
 joy... as an... of year



Fig 6

The "Devereux Heirloom"  
 Viscountess Herford

Costumer's Guild Meeting  
Feb 28th

Please note that the recommendations put forth here are just that, recommendations. Please comment on these. We want to make the ranking system more open to the populace. To accomplish this there needs to be input from all.

There were 12 members present. A costumer's Guild badge was thought to be important for recognition and morale. A hat badge was thought to be appropriate. Wolfgar will be approached on whether this is realistic and if we can get them for a good price. The badge will have the distaff of the Guild on it. The Guild member will then add a gemstone for the ranks accomplished. (see below for the gem recommended for each rank) Junior apprentice will be the level where the member will get a badge. The first order of business was to decide on the ranking levels. It was thought that 3 rankings were not enough. After much discussion the group decided on the below:

- Associate
- Junior apprentice - Badge
- Senior Apprentice - Garnet
- Journeyman - Amethyst
- Scholar - Pearl

Each level will have a basic requirement. To advance in ranking past Associate paid membership at the time of application and passing will be required. Each ranking will have other requirements that will be chosen from several lists (for example choose three from list A, two from list C etc.)

Basic Requirements

(12) From the Skin Out

Associate - Anyone that shows an interest in the Guild.

Junior Apprentice - Must have taken a class on some form of textile arts (name of teacher and the where you took it) or have documentation (needs not be primary for the garment that you have chosen to display as an example. Choose one example of your work from column B (see below for columns). This level non-juried.

Senior Apprentice - Documentation required for your examples and it must include primary sources. Choose 1 example of your work from column B, one from Column C, Two from column D and one other from any of the four columns.

Journeyman - Must demonstrate a broad knowledge of costume in the SCA time period. This can be through a project proposed by the candidate or a written test that will be developed by the Guild which ever the candidate chooses. Choose 2 from column A, two from column B, two from Column c, two from column D, and two from any of the four columns.

Scholar - Must present a scholars project. Chose three from each of the four columns and three from any of the four columns.

Each column has an emphasis. The below are just some of the examples of the thing that will qualify for each column. If you have something that is not listed but are sure that it would fit into one of the categories please contact the administrator with the details.

**Column A** - Writing and Teaching technical paper such as a HOW TO that is publishable in the FTSO  
Historical Paper that is publishable in the FTSO  
One on One teaching or teaching at a local level  
class taught on a kingdom level Ithra or Guild workshop  
Judging a kingdom level contest

**Column B** - Garments  
Underclothing (corsets, farthingales, small clothes, chemises, shirts, undertunics)  
coats/outerwear  
rectangular constructed garment  
tailored garment  
semi fitted garment  
Textile under armor wear

**Column C** - Accessories  
Shoes  
Gloves  
Make-up  
Hair  
Hats/headcoverings  
Jewelry/adornments (masks, fans, Pomanders, fleafurs, faceveils, etc.)  
Belts  
Bags/pouches  
stockings/hose  
Handkerchiefs  
Ruffs and muffs

**Column D**  
Class taken  
Banners/decoration  
Pavilion/household goods  
Icons/reliquaries/prayerbeads  
Entered Kingdom level contest  
Animal bardings  
Won local level contest  
Guild officer or deputy  
Significant time contribution to the guild

The point of the column system is to give the candidate a wide variety of choice in how they go about achieving the ranks. It was thought that choice was extremely important in developing a new ranking system. The jury system is yet to be worked out but it will be essentially the same as the old guild jury system, that being that the administrator and a qualified group of people will function as the jury until sufficient scholars have been created then the jury process will be taken over by them.

As was stated at the beginning this is just a proposal. All that attended the meeting are sure there are things that have been overlooked. Please send your comments to the administrator. We will have another meeting regarding this at the Guild faire and at May Crown.



Spring '93 (13)

**EASY WOODEN EMBROIDERY**

**STAND**

by Huebald ap Urp

**Pieces needed for Embroidery Stand**

**Lumber:**

- A Cap rail..... 1 x 25"
- B Bottom Rail ..... 1 x 27"  
2 x 18"
- C Spindles..... 2 x 32"
- D 1 x 2 k.d. fir..... 1 x 25"  
4 x 18"
- E 3/4" dowel ..... 2 x 23"

**Hardware:**

- F Carriage bolts ..... 2 x 1/4" x 2"
- G Wood screws..... 10 x 1-1/2"
- H Hanger bolts ..... 6 x 1/4" x 2-1/2"
- I Washers..... 8 x 1/4"
- J Wing nuts. .... 8 x 1/4"
- K Hinges. .... 2 x 1-1/2" wide
- L Lid supports..... 2

**EMBROIDERY RACK**

**STEP 1**

Drill the ends of the dowel (E) out to accept our of the hanger bolts (H). Add a little bit of wood glue to the hole before screwing in the hanger bolts(H). To get a hold of the hanger bolts, put on two of the wing nuts (J) back to back and lock

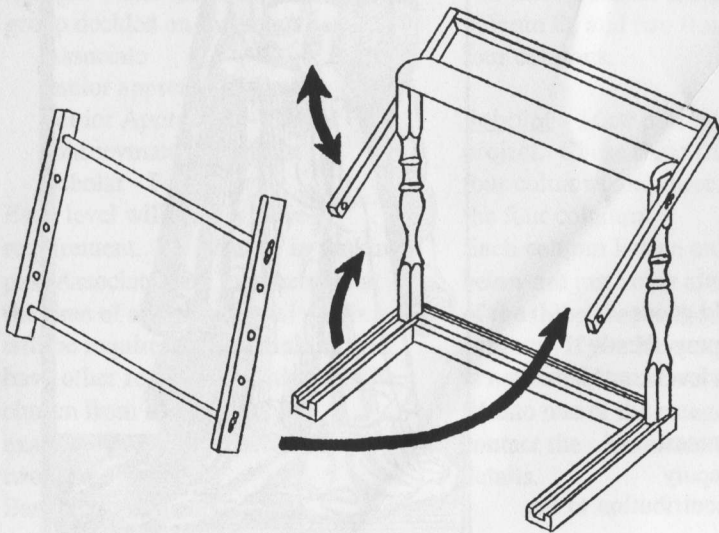

(14) From the Skin Out

them together, this will give you a temporary handle that won't crush the threads.

**Step 2**

Attach a thin strip of canvas-like material onto the length of the dowel (E) using a staple gun. This will allow your embroidery to be tacked onto the dowel so you can tighten your work.

**Step 3**

Next, take the 18" lengths of 1x2 (D) and drill holes one inch from the end, in the center of the wide side of the 1x2 (D) and drill holes one inch from the end, in the center of the wide side of the 1x2 (D) to accept the carriage bolts (F). Then drill another hole in the center of each piece of 1x2 (D) on the wide side at nine inches from the end.

**Step 4**

Assemble the dowel (E) into the holes at the ends of the 1x2 (D) and hold in place with four washers (I) and wing nuts (J). The embroidery rack is now finished.

**EMBROIDERY STAND**

**Step 1**

Take the cap rail (A) and trim it to fit the exact length of the embroidery rack. Also trim to the same size as the 1x2 (D) used in the embroidery rack. Also trim to the same size the 25" piece of 1x2 (D).

**Step 2**

Find the center of the cap rail (A) and mark it lightly with a pencil. Also find the center of the 27" bottom rail (B), and mark it similarly. Line the centers up so that they are even and mark the ends of the shorter cap rail (A) onto the top

side of the bottom rail(B). This will allow for the spindle (C) to be more or less square with the cap and bottom rails (A,B). Lay a spindle (C) in the slot of one of the shorter pieces of bottom rail (B). Holding the spindle and bottom rail (B,C) together, vertical to the 27" bottom rail, place the combination onto the longer bottom rail (B) lining it up with the pencil mark on the outside edge of the spindle (C). Now mark the inside edge of the shorter bottom rail (B) lining it up with the pencil mark on the outside edge of the spindle (C). Now mark the inside edge of the shorter bottom rail (B) onto the longer bottom rail (B). This will give you the markings to remove a notch out of the 27" bottom rail (B) to allow the feet of the stand to rest flush with the spindle (C) when down. Saw out this notch from the 27" bottom rail (B) making sure only to remove the wood from the moulded edge to the depth of the mark made previously. Repeat this procedure on the other end of the 27" bottom rail (B).

**Step 3**

Drill holes to accept the hanger bolts 1" from the top of the spindles (C) and add some glue then screw in the hanger bolts. Align the spindles (C), with the hanger bolts pointing to the outside, to their marks and drill two holes through the bottom of the 27" bottom rail for two screws (G) per spindle (C). Add a touch of wood glue to the bottom of the spindles (C) and inside the holes. Screw the bottom rail (B) onto the spindles (C) and wipe up the excess glue.

**Step 4**

Drill holes to fit the carriage bolts 1" from one end and holes to fit hanger bolts 5" from the other end of both of the 18" 1x2 (D). Take the remaining 1x2 (D) and align them into a "U" formation with the adjusted 25" 1x2 as the base of the "U" and the other two pieces covering the ends of the longer 1x2 (D). Make sure the end of the 18" 1x2 (D) with the hole 5" from the end, is toward the base of the "U". Drill out two screw holes on each end, add glue, screw together and wipe off excess glue.

**Step 5**

Place the "U" around the hanger bolts at the top of the spindles (C) using the holes in the "U" that are near the base of the "U". Now align the cap rail (A) to the edge of the spindles (C) and drill one hole for a screw, glue, screw, glue, screw and wipe off the excess glue.

**Step 6**

With the basic frame of the stand complete, stand the frame up and slide the feet into place and lay the hinges (K) in the joint of the feet and spindles (C). Mark the holes for the hinges (K) and drill, glue, screw and wipe off the excess glue. Attach the lid supports (L) at a 45 degree angle using the same, mark, drill, glue, screw and wipe procedure.

**Step 7**

Slide the carriage bolts through the middle hole in the rack so they point to the outside. Attach the rack to the holes at the end of the "U" with a washer (I) and wing nut (J) and the stand is now complete.

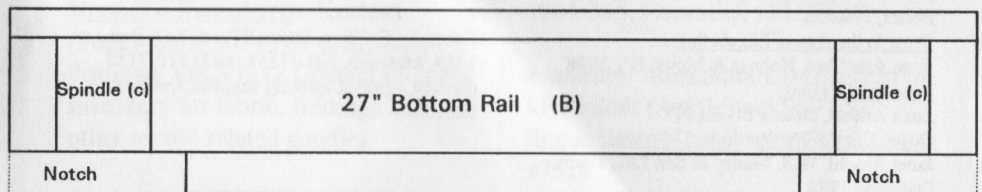

## Books and Sources

Compiled by

Mistress Katryne of Hindscroft

### General reference books:

#### 20,000 years of Fashion

Francois Boucher, Harry N. Abrams, Inc, NY 1987

#### The Visual History of Costume

Aileen Ribeiro & Valerie Cumming, B.T. Batsford Ltd., London 1989

#### The Book of Costume

Millia Davenport, Crown Publishers, Inc., NY 1976

#### History of Costume

Blanche Payne, Harper & Row, NY 1965

#### A survey of Historic Costume

Phyllis Tortora and Keith Eubank, Fairchild Publications, NY 1989

### Special Reference Books

#### Tailor's Pattern Book 1589

Juan de Alcega, Ruth Bean, Carlton, Bedford 1979

#### Corsets and Crinolines

Norah Waugh, Routledge Theatre Arts Books, NY 1991

#### Period Costume for Stage and Screen

Jean Hunnisett, Bell & Hyman, Ltd., 1986

#### Patterns for Theatrical Costume s

Katherine Strand Holkeboer, Prentice-Hall, Inc. 1984

#### Ancient Greek, Roman and Byzantine costume & Decoration

Mary G. Houston, Adam & Charles Black, London 1947

#### Late Gothic Europe, 1400-1500

Margaret Scott, Humanities Press, NJ 1980

#### Renaissance Dress in Italy 1400-1500

Jacqueline Herald, Humanities Press, NJ 1981

#### Hispanic Costume 1480-1530

Ruth Matilda Anderson, The Hispanic Society of America, NY 1979

#### Dress in Ireland

Mairead Dunlevy, Holmes & Meier Publishers, Inc., NY 1989

#### The Costume of Scotland

John Telfer Dunbar, B.T. Batsford Ltd., London 1989

#### Fashions Through the Centuries

(Czech Costuming) Olga Stronkova Spring Books, London

#### Dress in the Age of Elizabeth I

Jane Ashelford, Holmes & Meier, NY 1988

#### Patterns of Fashion

Janet Arnold, Drama Books, NY

#### Queen Elizabeth's Wardrobe Unlock'd

Janet Arnold, W.S. Maney & Son Ltd., Leeds, England 1988

### Sources of Books

College Libraries (especially if they have a drama or textiles department)

for loan. Please never take something out on "permanent loan".

The Scholar's Bookshelf, 51 Everett Drive, Princeton Jct., NY 08550

Hacker Art Books, Inc., 45 West 57 Street, New York, NY 10019

Barnes & Noble, 126 Fifth Ave., New York, NY 10011

Unicorn Textiles and Books for Craftsmen, 1338 Ross Street, Petaluma, CA 94954-6502. 1-800-289-9276.

Various University Presses

Used Book Stores

### Mail Order Sources

Kathleen B. Smith Textile Reproductions, Box 48, West Chesterfield, MA 01084 (413) 296-4437 (Linen fabrics, sewing tools, natural dyed embroidery threads, trimmings, and books.)

Threadneedle Street, 35 W. Sunset Way, Suite B, Issaquah, WA 98027 (206) 391-0528 (Threads, evenweave fabrics, embroidery accessories, and books.)

Greenberg & Hammer, Inc., 24 West 57th Street, New York, NY 10019 (212) 246-2835 (Corset bones, Hoop boning, dressmaker supplies and sewing notions)

Beggars' Lace, P.O. Box 481223, Denver, CO 80248 (303) 722-5557 (Lacemaking supplies and books)

Robin and Russ Handweavers, 533 North Adams Street, McMinnville, OR 97128 (503) 472-5760 (Weaving supplies, Lacemaking supplies and books.)

Raiments, P.O. Box 6176, Fullerton, CA 92634-6176 (Millinery supplies, Costume accessories, Patterns and books.)

Hedgehog Handworks, 8406 Flight Avenue, Los Angeles CA 90045 (Embroidery threads, evenweave fabrics, needlework supplies, and books.)

Keepsake Quilting, Dover Street, P.O. Box 1459, Meredith, NH 03253 (603) 279-7115 (sewing supplies, quilting supplies, quilting fabrics)

### Costumgr's Guild Dirzctory

The Guild offers a buying service, library, information exchange and guild ranking.

Guild Membership is 12.00/year and includes a subscription to the F.T.S.O., and a discount at the Drapers. You must be a member in good standing to challenge the guild rankings. All are welcome to participate in Guild workshops, contests and other activities regardless of membership status.

Administrator: Eduardo Lucrezia (D.S. McDonald) 2648 B Laukala Pl., Enumclaw, WA 98022 (206) 825-3218 Contact Administrator for any information regarding the Guild. Send all new or re-renewal memberships to the administrator.

Librarian: Girard de Beauchamp (Gary Brock) 1102 NW 73rd ST., Seattle, WA 98117 (206) 782-2549 Contact Librarian for book list and loaning policy.

### Education Coordinator/Contest

Deputy: Isolde de la Vielle-a-Roue (Alisandra Davis) 3624 Serene Way, Lynnwood, WA 98037 (206) 743-3318 Contact Education Coordinator regarding workshops and classes. Contact Contest Deputy regarding all Guild contests or for a copy of the guild judging form.

Drapers Inventory: Koressa (Foggy Bell) 3634 NE 19th Ave., Portland, OR 97212 Contact Drapers inventory for fabric, findings and other textile related goodies.

Exchequer: Lee of the Lowland

(Lee Humason) 14346 20th NE Seattle, WA 98125 (206) 365-0413

Editor of the From the Skin Out: Anastasia Alexandrovna Andreeva (Marilee G. Humason) 14346 20th NE Seattle, WA 98125 (206) 365-0413 Submissions gratefully accepted. An extension of one issue will be added to your membership for contributing to the FTSO The F.T.S.O. is published four times a year and comes out at each Crown event. Send all new or re-renewal memberships to the administrator.

Contact your regional representatives for local activities or sources in your area.

Avacal: (Temporary Representative) Eirika Pacchioni from Montengarde (Janett Anderson) #-2039 34th Ave., Calgary AB T2T 2C4 Canada (403) 246-8976

Inlands: Nikita van Dantzig from Wealdsmere (Lynda Petty) E 4327 Princeton, Spokane WA. 99207 (509) 483-1570

Northern: Sine ni Guinne from Ramsguard (Janis M. Cliffe) 1615 Slater Ave., Kamloops, B.C. V2B 4K3 Canada (604) 3765243

Rivers: Karena di Falco from Coeur du Val (Alison Kondo) P.O. Box 3004-245, Corvallis, OR 97339

Summits: Rosemary Craftwise from Myrtleholt (April Stockley) 252 SW Rogue River Ave. Grants Pass, OR 97526

Western: Murkami Tsuruko from  
Dragon's Lair (Deborah Strub) 7205  
Thasos AVE. NE Bremerton, WA  
98310 (206) 692-5885

Deputies

Deputy Administrator/  
Recording Secretary: Olwen Pen  
Aur (Jo Ann Turner) P.O. Box 1475  
Oliver, B.C V0H 1T0 Canada

Deputy Administrator: Alena  
Maria Magdalena d'Firenze (Sharon  
Burrows) 2621 St George ST.,  
Vancouver, B.C. V5T 3R5 Canada



Embellisher's Sub-Guild:  
Administrator: Shirin al Hasan  
(Leanne Folger) #49-9960 Wilson  
Rd., RR #7, Misson B.C. V2V 6H5  
Canada

Weaver's Sub-Guild:  
Administrator: Colleen Campbell  
(Samantha Will) 851 NE Ainsworth,  
Portland OR 97211 (503) 288-0838

Anted Thread Patterns from Nicolo Zoppino's "Univerali" - 1537

